

HYC PRECISION ENGINEERING

HYC Precision Engineering is located in the industrial city of Chennai, India. HYC provides comprehensive turnkey solutions in precision machining, assembly and testing, along with onsite field service engineering for industrial automatic testing equipment.

We are dedicated to enhancing HYC's ability to serve its customers in India and globally in an effectively and timely manner, while ensuring high-quality service and innovative engineering solutions.





Chennai CNC Facility

Our Services

We are your one-stop partner for precision CNC component manufacturing offering complete CAD/CAM support, advanced machining, surface treatments, mechanical assembly, and rigorous quality inspection to ensure accuracy from start to finish.

High - Precision Machining Equipment:

- 4x Brother - S500Z1 VMC Machine
- 6x Brother - S700Z1 VMC Machine
- 1x HUAYI - HY-5H Milling Machine



Secondary Surface Treatments:

- Sandblasting
- Anodizing
- Plating
- Powder Coating
- Hardening
- Laser Texturing
- Spray Painting

Any other secondary treatment services can be arranged.

Materials Capabilities

- Stainless Steel: SUS303, SUS304, SUS316
- Aluminum: AL6061-T6, AL6063, AL7000
- Alloy & Tool Steels: P20, SAE1018, AISI 4340, C45,
- High-Performance Plastics: PEEK, PPS, PEI
- Engineering Plastics: PTFE, POM, Nylon, Delrin (Black), ABS, Bakelite, TPU,
- Others: Brass, Copper, Zinc, Bronze, MS, SPCC, Polyurethane, Polyamide, Carbon Fibre, Titanium



Quality Assurance

Quality Inspection Instrument:

- Coordinate Measuring Machine (CMM)
- Vision Measuring Machine (VMM)
- Plunger Dial Gauge
- Height Gauge
- Bore Gauge
- Bevel Protractor
- Gauge block set
- Digital Vernier Caliper
- Digital Micrometer
- Feeler gauge
- Thread Plug Gauge
- Dial Test Indicator

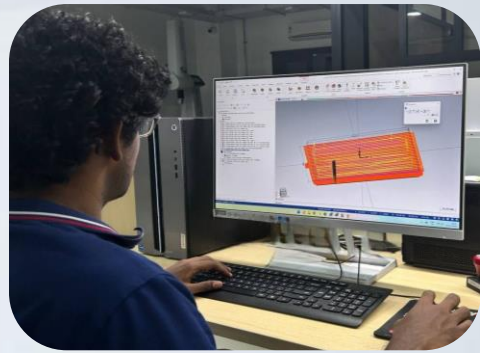

All quality inspection instruments undergo calibration by ISO 17025 accredited laboratories.

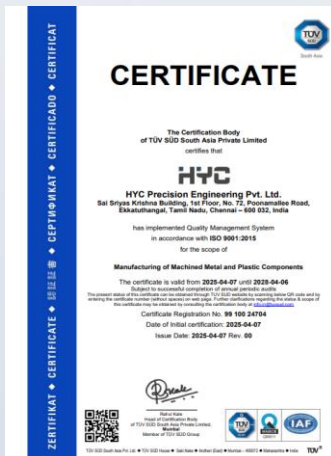

HYC has established a documented Quality Management System that adheres to the ISO 9001:2015 standard.

We aim to meet our internal and external customer requirements the first time and every time.

Automation Solution

We specialize in custom automation systems that transform manual or semi-manual processes into efficient, repeatable, and traceable operations.

Whether it's assembly, packing, part handling, or marking, our automation team integrates mechanical, electrical, and software expertise to build systems tailored to your needs.

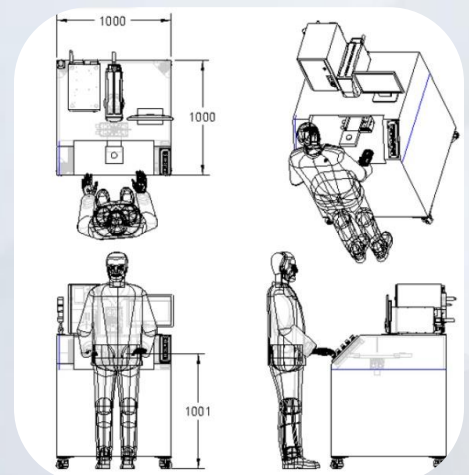

On-Site Support Service

We offer comprehensive on-site support service, delivered by a team of highly skilled professionals dedicated to ensuring the smooth operation of your equipment and systems. From installation to troubleshooting, our services are designed to maximize uptime, optimize performance, and enhance your operational efficiency.

Services Include:

- Installation & Setup: Smooth commissioning for optimal performance.
- Troubleshooting & Repair: Quick fault diagnosis and resolution.
- Preventive Maintenance: Extend lifespan and reduce disruptions.



Comprehensive
One-stop Solution



Timely and
Accurate Delivery



Professional
Technical Support

Jennifer Wu

Executive Director
+91 89177 37977
jenniferw@hyc.com

Adeline Soh

Director
+91 96820 94164
adelines@hyc.com

Ashwin U

Business Development
+91 74015 90668
ashwinu@hyc.com



India Office:

Chennai

Sai Sriyas Krishna Building, First Floor
No. 72, Poonamallee Road, Ekkatuthangal.
Chennai 600032, Tamil Nadu, India

Delhi

A-66, Ground Floor, DDA Shed,
Okhla Industrial Area Phase-II,
New Delhi 110020

