



PANOPLY

Panoply Packagings Pvt Ltd

Manufacturers of Corrugated Boards & Boxes

Company History:

- In this field for more than **30 years**.
- The Group Started Corrugated Box manufacturing as Small Scale Industry in the year 1987 and by the year 1996 – had three factories namely – **Bafna Packaging Industries, Kraft Containers and Bafna Packagings Pvt. Ltd.**
- **Bafna Packagings** was the first Packaging Company in this region to get **ISO 9002 Certificate**.
- **Bafna Packagings Pvt. Ltd.** has been merged with **Panoply Packagings Pvt. Ltd.** and is now located under one roof at **Sriperumbudur**.

Few Achievements Over The Years:

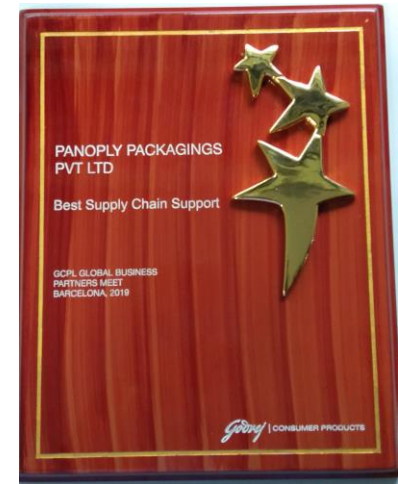
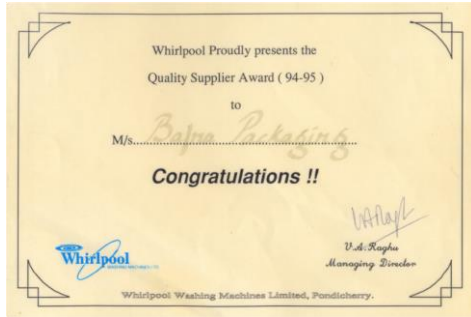

Current Facility:

- Panoply has a large manufacturing unit strategically located in **Sriperumbudur, Chennai** to cater to the large industrial belt in this area.
- Spread over **9 acres**, the factory is equipped with state-of-the-art manufacturing equipment. Built area of over **2,00,000 sq.ft.**
- Panoply is **ISO 9001-2015 certified** and follows it in all processes in every aspect of manufacturing.
- A large portion of the raw material is imported from reputed **paper mills from all over world.** This makes the final product of high strength and superior finish.



Solar Plant :

- **A 400 KWP solar plant** installed in order to become more sustainable.
- Panels located on roof in a such a way that it **reduces the heat** radiation falling directly on the roof and hence reducing the temperature inside.

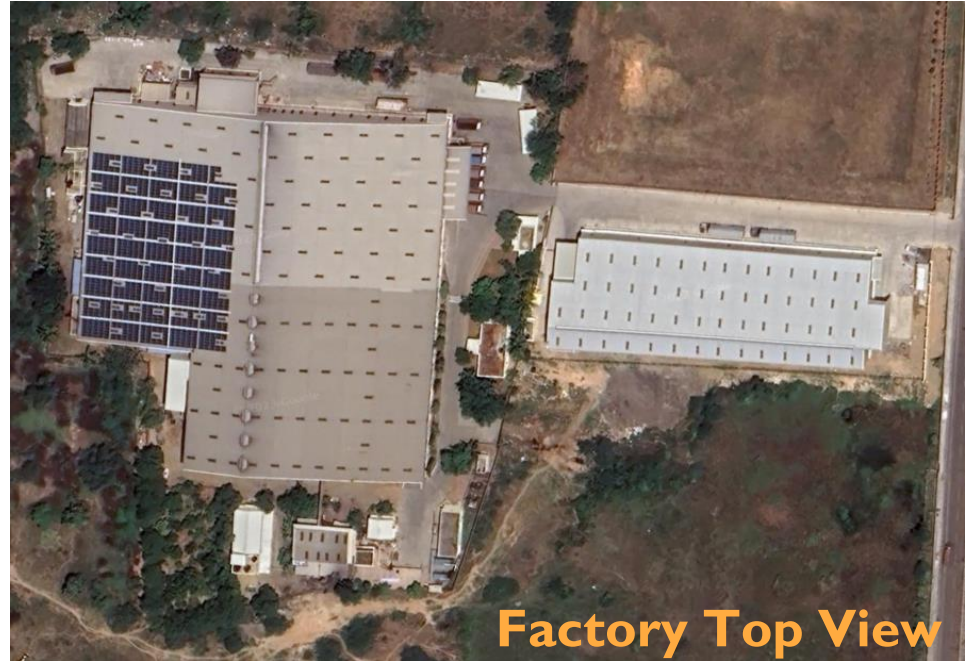

Capabilities:

Panoply provides packaging boards and boxes of various configurations listed below,

- **A, C, B** and **E** single wall.
- **AC, AB, BC, BE** and **CE** double wall.
- **AAC, ACA, ABC** triple wall.
- Boards can be manufactured in **2000 mm** width, with cut length of up to **4500 mm**.

Corrugator/Board Maker:

- Taiwanese automatic Corrugated Board Making Line with **A, C, B & E** Flute Board Making Capability or any combination of the mentioned Flutes to make a **3-Ply or 5-Ply** board with speeds up to **150 m/min**.



Converting Machines:

- A Casemaker from **BOBST**, France named **FFG 8.20 Discovery** with speeds up to **18,000 boxes/hr.**



- Another high speed specialty folder gluer from BOBST, more suitable for smaller size boxes and lock bottom die-cut boxes.



- Stand alone taping machine with hot melt glue and double sided tape application capabilities.

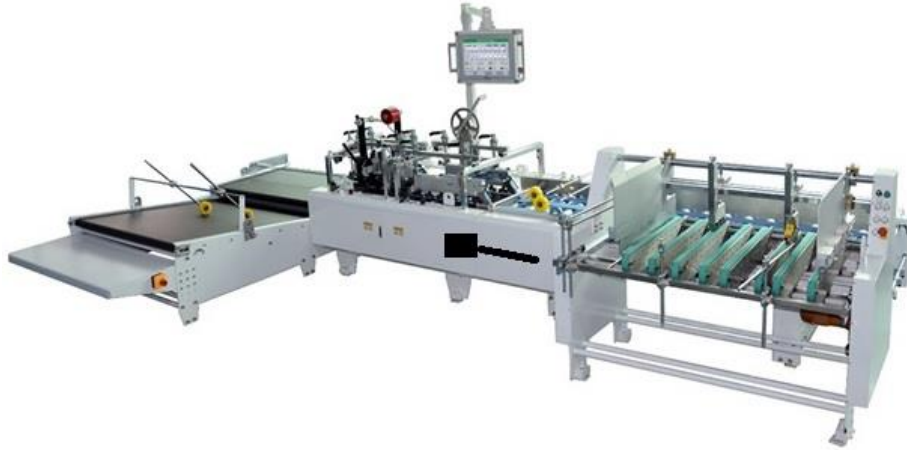

External double sided tape for closing the box

Central tear tape for opening the box

Internal double sided tape for closing the box again and sending it back.

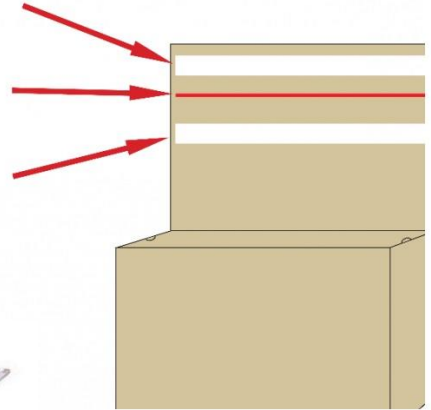

- High quality 4-Colour printer from Taiwan with speeds up to 220 sheets/minute.



- **Jumbo Size 2-Colour Printer Slotter Die Cutter** from Taiwan with speeds up to **150 sheets/minute**.

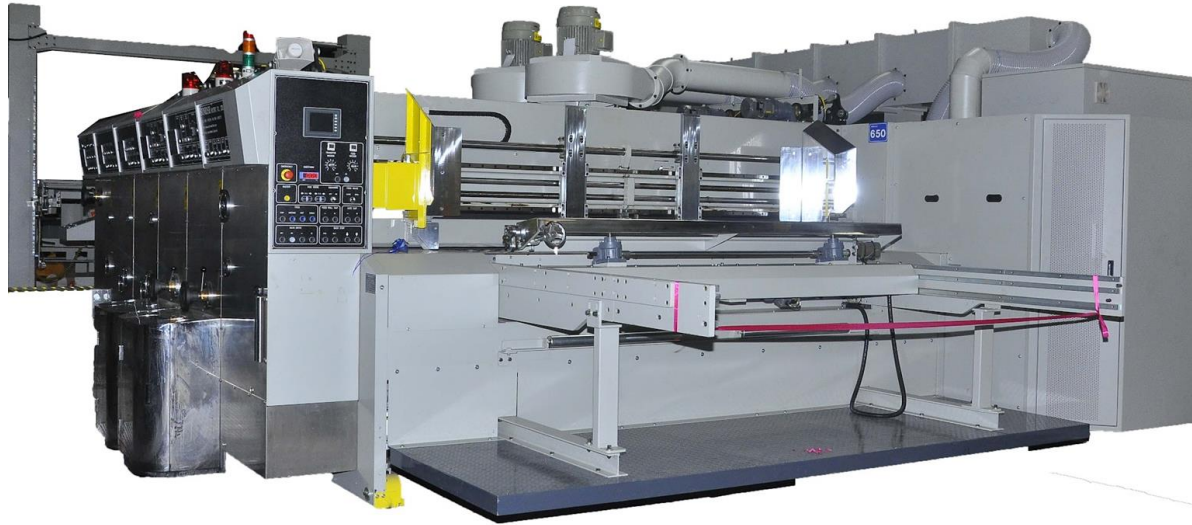

- 2 Fully Automatic Flat-Bed Die Cutters with Stripper from Taiwan with speeds of **4,500 impressions/hour** and **5,500 impressions/hour**.



Sample Making:

- Digital cutting table from **Europe** for fast and accurate sample making.

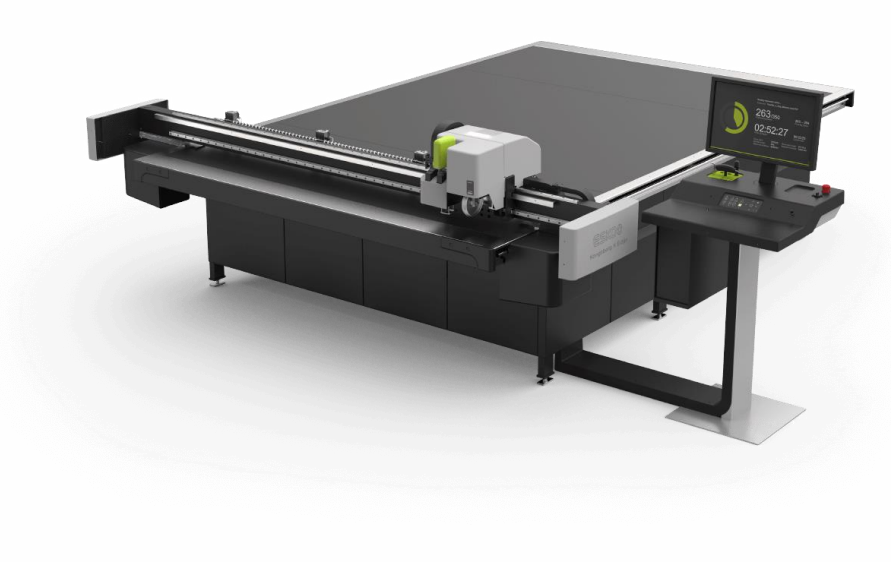

Other Machinery:

- A **4-Ton** capacity **Boiler** for providing steam for the board making process.
- A **fully automatic glue kitchen** to maintain consistency and minimum wastage.
- An **automatic Folder Gluer** from China with speeds up to **150 boxes/minute**.
- An **automatic Stitching machine** for very large size boxes.
- A **semi-automatic gluer** for very large size boxes.
- **Two Platen Punching** machines for Partitions and other small requirements.

- **Corrugated waste baler** for handling waste.
- **Wastewater treatment plant.**
- **Many other supporting equipment** to improve the efficiency, cleanliness and for easy maintenance of the plant. Eg- **Forklifts, Palletizer, Pre-feeder, etc.**

Quality:

- A Quality Lab with all the best testing machines is available and dedicated towards continuous quality checks and quality improvement.
- A **GSM Tester, Bursting Strength Tester, Box Compression Tester, COBB Value Tester, ECT Tester, RCT Tester** are all available for paper and box testing.
- Other testing equipment such as **Zahn Cups** for ink viscosity checking and Moisture Content tester are continuously used in process to maintain the quality.

Fire Hydrant System:



- Fire fighting equipment installed for safety. Periodic training is given for operation and safety.

Training Facilities:

- Regular employee training conducted internally and by external agencies.



- For the Health & Safety of all employees periodic first aid training is given.



Employee Appreciation:

- Employees performing well are recognized and appreciated.



Contact:

PANOPLY PACKAGINGS PVT. LTD.

Survey No.205 & 206 Aarneri Village, Pondur BO,

On Sriperumbudur Oragadam Road, Near Little Flower HS School,

Sriperumbudur – 602 105

Chennai, Tamil Nadu

Tel: +91 63840 01155/66/77

E-mail: panoplypackagings@gmail.com

Director- Technical & Marketing - Mahaveerchand Jain (+91 98402 14033)

Business Development Executive - Neeraj Bafna (+91 89390 54452)