



GANZ TECHNIK



www.ganztechnik.in

Ganz technik, established in 2016 . We are Designing and Manufacture a wide range of winding solution like:

Electrical and Electronical solution Provider

- Automatic hook Winding solution
- Automatic Glue Dispensing Solution
- Automatic Dip soldering solutions
- Automatic core Taping Solution
- Toroidal Taping Solution

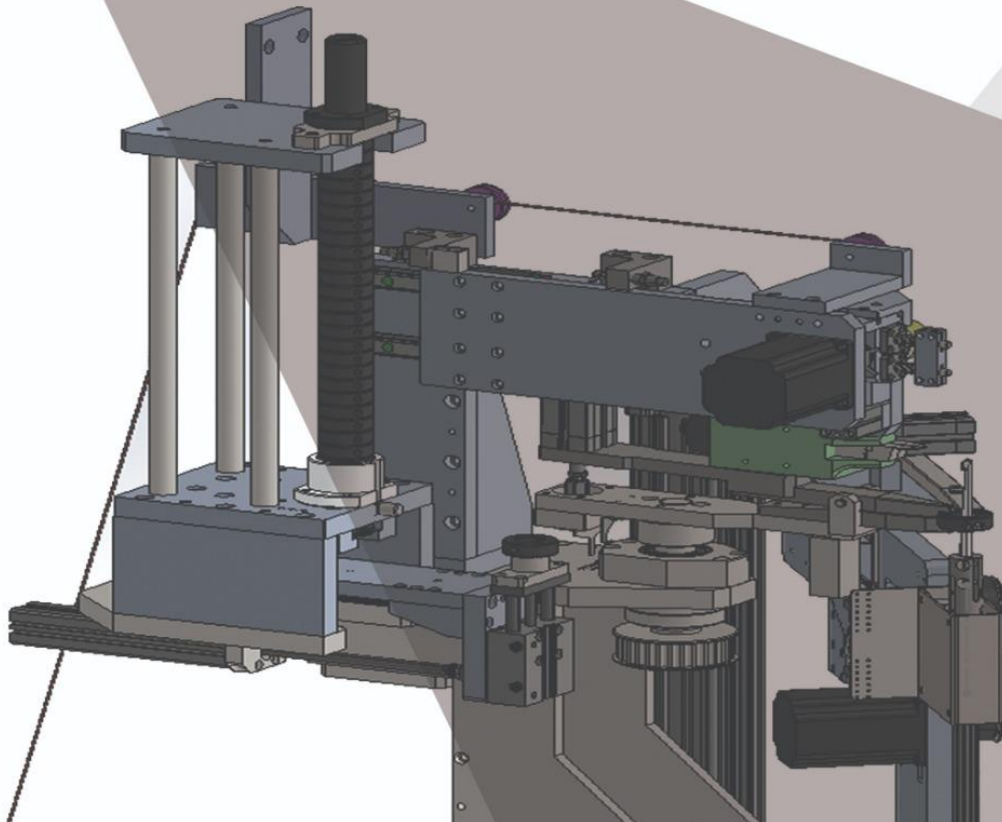

AUTO HOOK WINDING MACHINE SPECIFICATIONS

Our Auto Hook Winding Machine is mainly composed of a single chute feeder, clamping mechanism, Auto coil feeder and winding mechanism. The working principle is that the motor drives the winding mechanism to rotate, and the copper wire is wound around the core to obtain the required winding with the help of spinning mechanism and pneumatically operated hook. Thus the system provides fully automated mechanisms for coil winding using motorised arrangements and pneumatic cylinders.



FULL COIL WINDING

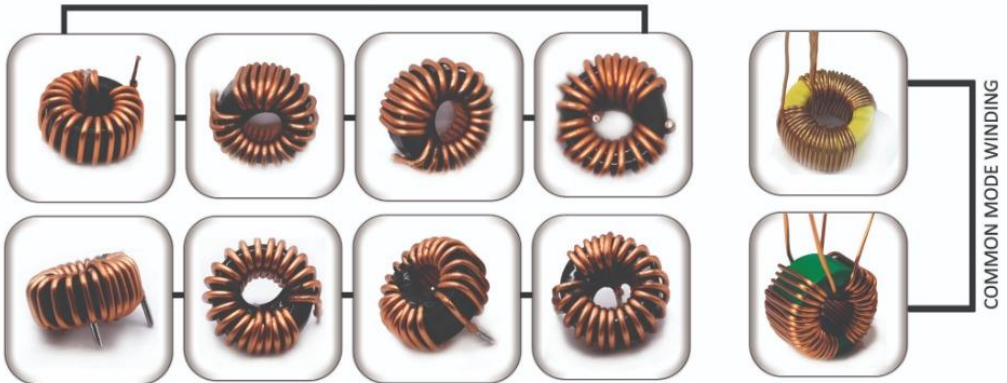

We classified the machine as three types with respect to the wire diameter to be wound on the core.

AUTO HOOK WINDING MACHINE TYPES					
S.NO	MACHINE PART NUMBER	COIL DIA	WIRE LENGTH	CORE DIA	
1	GTAHW-0.5	0.3 - 0.5	500 MAX	MIN 10	MAX 40
2	GTAHW-01	0.5 - 1	800 MAX		
3	GTAHW-1.5	1 - 1.5	1000 MAX		

Machine Technical Specifications		
1	PRODUCTION COUNT	PROVIDED
2	POWER FAIL SAVE	COUNTER WILL NOT RESET
3	WIRE GAUGES	30 SWG- 17 SWG - SINGLE/MULTI WIRE CAN WIND
4	CORE OUTER DIAMETER	15-50 MM DIAMETERS
5	CORE INNER DIAMETER	5 MM-40MM
6	CORE HEIGHT	8MM- 20 MM
7	HOOK- UP/DOWN, OPERATING	AUTO
8	SEGMENT WINDING	PROVIDED 60-360 DEGREE, PROGRAMMABLE
9	WINDING PITCH ADJUST	PROVIDED ONLINE
10	EVERY LAYER STOP	ONLINE- SWITCH PROVIDED
11	DISPLAY	HMI
12	CORE FIXING JAWS	CUSTOMISABLE
13	SUPPLY	220V 50HZ 1 Phase
14	WINDING SPEED	DEPENDS ON THE OPERATOR SPEED MAX 30 RPM
15	TOTAL TAPS	8 TAPS EACH PROG PROVIDED
16	CORE INDEX MOTOR	STEPPER MOTOR WITH DRIVE
17	ONLINE CORE ADJUSTMENT	ONLINE SWITCH PROVIDED
18	TURNS INDICATION	ONLINE DISPLAY
19	CONTROLLER SECURITY	PASSWORD OPTION PROVIDED
20	MACHINE DIMENSION	CUSTOMISABLE
21	HOOK	STEEL/NYLON HOOK 6MM/8MM DIAMETER
22	HOOK HOLDER	ADJUSTABLE UPTO 10MM DIAMETER
23	MACHINE WEIGHT	APPROXIMATELY 300 KGS

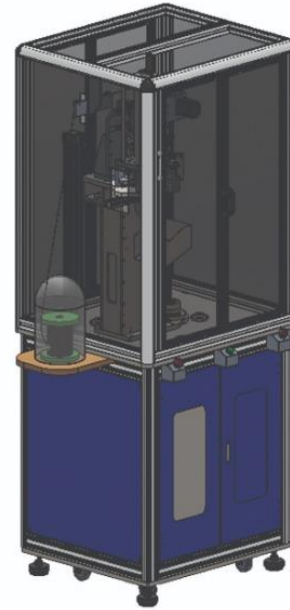

Registration Address:

22,2nd Cross Street,
Krishnapuram, Nandhivaram, Guduvanchery,
Chennai-603202

info@ganztechnik.in

www.ganztechnik.in



GANZ TECHNIK

